

COMPONENTS FOR SOLAR THERMAL SYSTEMS

The diagram is just an indication

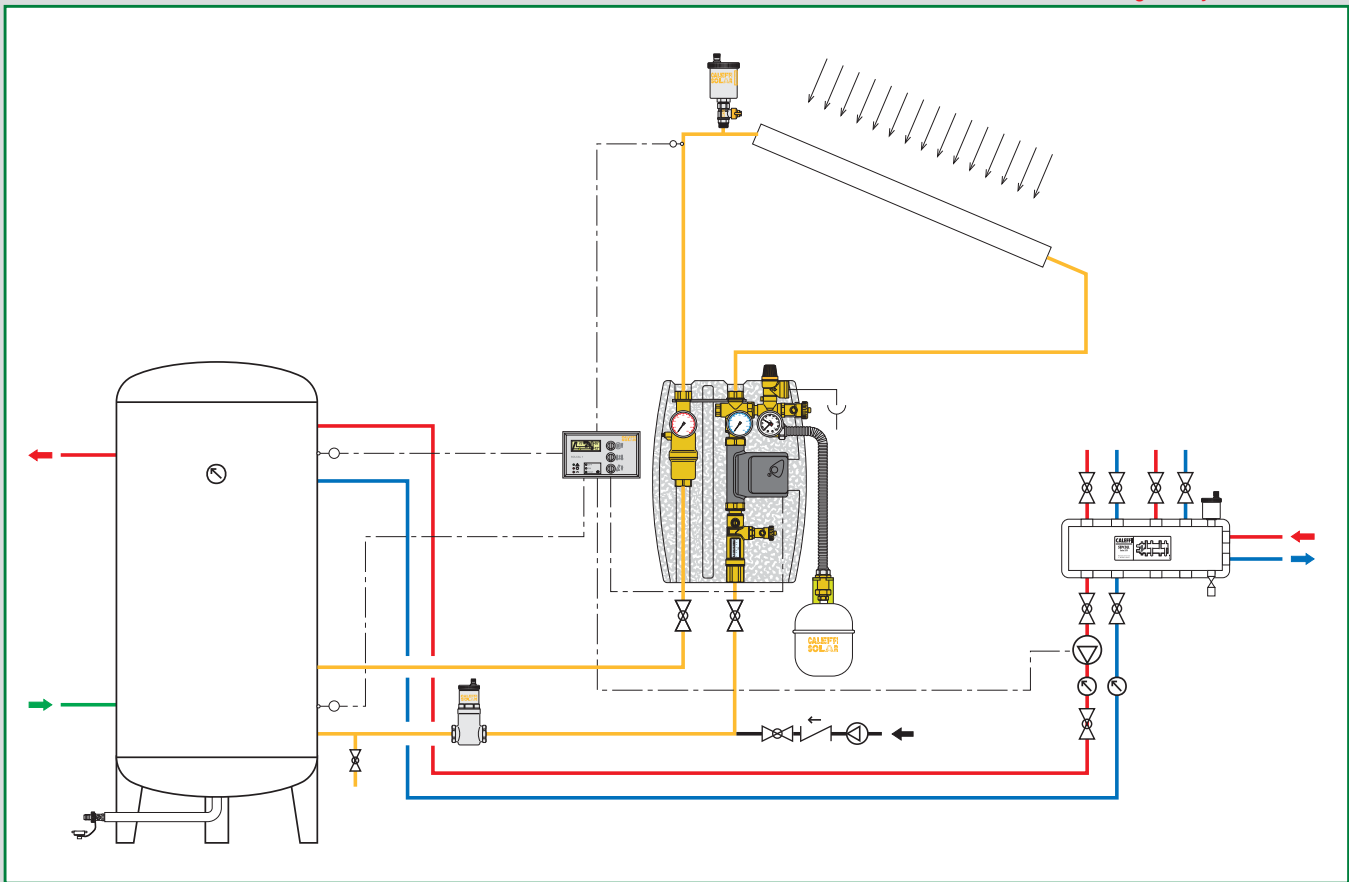

6A

	SERIES
Safety relief valve - air vent	253, 250
Deaerators	251, 250
Pump stations	267, 266, 269, 268
Accessories for pump stations	259, 255
Ball valve and three-piece union fitting	240, 588
Digital controller, SOLCAL 1	257
Differential regulators and thermostat	257, 150
Mechanical fittings with O-Ring seal	2540, 2543, 2544, 2545, 2547, 2548
Pump stations with heat exchanger	260, 261
Heat meter, CONTECA SOLAR	75525
Balancing valve with flow meter	258
Thermostatic mixing valves	2521, 2523
Anti-scald tempering and thermostatic mixing valves	2522, 2527
Motorised ball diverter valve	6443
Solar storage-boiler connection kit, SOLARNOCAL	264
Solar storage-boiler connection kit, SOLARINCAL	265
Solar storage-boiler thermostatic connection kit, SOLARINCAL-T	262
Solar storage-boiler thermostatic connection kit, SOLARINCAL-T PLUS	263
Temperature and pressure relief valve	309
Anti-freeze safety device, ICECAL®	603

CALEFFI SOLAR

Caleffi Solar product range has been specially developed for use in solar thermal systems, where high temperatures can normally be reached and where, depending on the kind of system, the water can be mixed with glycol. Materials and performance of the components must necessarily take into account these particular operating conditions.

SAFETY RELIEF VALVE - AIR VENT



253

tech. broch. 01089

Safety relief valve for solar thermal systems.
 Brass body. Chrome plated.
 Female connections. PN 10.
Temperature range: -30÷160°C.
Max. percentage of glycol: 50%.
 Oversized discharge outlet.
 Power discharge rating: 1/2" - 50 kW;
 3/4" - 100 kW.

TÜV certified to SV100 7.7
 No. TÜV SV 07 2009 • SOL • H • p.
 Settings: 2,5 - 3 - 4 - 6 - 8 - 10 bar.



250

tech. broch. 01133

Consisting of:
 - Automatic air vent for solar thermal systems.
 Brass body. Chrome plated.
 Max. working pressure: 10 bar.
 Max. discharge pressure: 5 bar.
Temperature range: -30-180°C.
Max. percentage of glycol: 50%.
 - Shut-off cock complete with seal.
 Brass body. Chrome plated.
 Max. working pressure: 10 bar.
Temperature range: -30-200°C.
Max. percentage of glycol: 50%.



Code

Code	1/2" F x 3/4" F	2,5 bar	1	50
253042	1/2" F x 3/4" F	2,5 bar	1	50
253043	1/2" F x 3/4" F	3 bar	1	50
253044	1/2" F x 3/4" F	4 bar	1	50
253046	1/2" F x 3/4" F	6 bar	1	50
253048	1/2" F x 3/4" F	8 bar	1	50
253040	1/2" F x 3/4" F	10 bar	1	50
253052	3/4" F x 1" F	2,5 bar	1	25
253053	3/4" F x 1" F	3 bar	1	25
253054	3/4" F x 1" F	4 bar	1	25
253056	3/4" F x 1" F	6 bar	1	25
253058	3/4" F x 1" F	8 bar	1	25
253050	3/4" F x 1" F	10 bar	1	25

The automatic air vent must be shut off after the system has been filled.



Code

Code	3/8" M	without cock	1	25
250031	3/8" M	without cock	1	25
250131	3/8" M		1	25

DEAERATORS



251 DISCAL®

tech. broch. 01134

Deaerator for solar thermal systems.
Brass body. Chrome plated.
Female connections.
Max. working pressure: 10 bar.
Max. discharge pressure: 10 bar.
Temperature range: -30-160°C.
Max. percentage of glycol: 50%.

Code

251003 3/4" F



1 10



251 DISCALAIR®

tech. broch. 01135

High-performance automatic air vent for solar thermal systems.
Brass body. Chrome plated.
Female connection.
Max. working pressure: 10 bar.
Max. discharge pressure: 10 bar.
Temperature range: -30-160°C.
Max. percentage of glycol: 50%.

Code

251004 1/2" F



1 10



251 DISCAL®

Deaerator for solar thermal systems.
Brass body. Chrome plated.
Female connections.
With drain.
Max. working pressure: 10 bar.
Max. discharge pressure: 10 bar.
Temperature range: -30-160°C.
Max. percentage of glycol: 50%.

Code

251006 1" F

251007 1 1/4" F



1 -

1 -



250

tech. broch. 01133

Shut-off cock complete with seal.
Brass body. Chrome plated.
Max. working pressure: 10 bar.
Temperature range: -30-200°C.
Max. percentage of glycol: 50%.



Code

250300 3/8" M x 3/8" F - butterfly handle

250400 1/2" M x 1/2" F - lever handle



1 10

1 10

PUMP STATIONS

267

Pump station for solar thermal systems, flow and return connection, **with solar controller**.
 Supply: 230 V (ac).
 Max. working pressure: 10 bar.
Safety relief valve temperature range: -30–160°C.
 Safety relief valve setting: 6 bar (for other settings, see 253 series).
Balancing valve with flow meter temperature range: -30–130°C.
Max. percentage of glycol: 50%.

- Consisting of:
- Solar 15-80 circulation pump;
 - safety relief valve for solar thermal systems 253 series;
 - 2 fill/drain cocks;
 - instrument holder fitting with pressure gauge;
 - balancing valve with graduated scale flow meter with magnetic movement flow rate indicator;
 - deaerator device;
 - flow temperature gauge;
 - return temperature gauge;
 - 2 shut-off valves and check valve;
 - pre-formed shell **insulation**;
- digital controller DeltaSol® C+ with probes.



267

Pump station for solar thermal systems, flow and return connection.
 Supply: 230 V (ac).
 Max. working pressure: 10 bar.
Safety relief valve temperature range: -30–160°C.
 Safety relief valve setting: 6 bar (for other settings, see 253 series).
Balancing valve with flow meter temperature range: -30–130°C.
Max. percentage of glycol: 50%.

- Consisting of:
- Solar 15-80 circulation pump;
 - safety relief valve for solar thermal systems 253 series;
 - 2 fill/drain cocks;
 - instrument holder fitting with pressure gauge;
 - balancing valve with graduated scale flow meter with magnetic movement flow rate indicator;
 - deaerator device;
 - flow temperature gauge;
 - return temperature gauge;
 - 2 shut-off valves and check valve;
 - pre-formed shell **insulation**.



Code	Flow meter scale (l/min)		
267250	3/4" F 2– 7	1	–
267254	3/4" F 3–10	1	–
267252	3/4" F 7–25	1	–

Code	Flow meter scale (l/min)		
267050	3/4" F 2– 7	1	–
267054	3/4" F 3–10	1	–
267052	3/4" F 7–25	1	–

PUMP STATIONS

266

Pump station for solar thermal systems, return connection, **with solar controller**.

Supply: 230 V (ac).

Max. working pressure: 10 bar.

Safety relief valve temperature range: -30-160°C.

Safety relief valve setting: 6 bar (for other settings, see 253 series).

Balancing valve with flow meter temperature range: -30-130°C.

Max. percentage of glycol: 50%.

Consisting of:

- Solar 15-80 circulation pump;
- safety relief valve for solar thermal systems 253 series;
- 2 fill/drain cocks;
- instrument holder fitting with pressure gauge;
- balancing valve with graduated scale flow meter with magnetic movement flow rate indicator;
- return temperature gauge;
- shut-off valve and check valve;
- pre-formed shell **insulation**;

- digital controller DeltaSol® C+ with probes.



266

Pump station for solar thermal systems, return connection.

Supply: 230 V (ac).

Max. working pressure: 10 bar.

Safety relief valve temperature range: -30-160°C.

Safety relief valve setting: 6 bar (for other settings, see 253 series).



Balancing valve with flow meter temperature range: -30-130°C.



Max. percentage of glycol: 50%.

Consisting of:

- Solar 15-80 circulation pump;
- safety relief valve for solar thermal systems 253 series;
- 2 fill/drain cocks;
- instrument holder fitting with pressure gauge;
- balancing valve with graduated scale flow meter with magnetic movement flow rate indicator;
- return temperature gauge;
- shut-off valve and check valve;
- pre-formed shell **insulation**.



Code	Flow meter scale (l/min)		 	
	3/4" F	2- 7	1	-
266250	3/4" F	2- 7	1	-
266254	3/4" F	3-10	1	-
266252	3/4" F	7-25	1	-

Code	Flow meter scale (l/min)		 	
	3/4" F	2- 7	1	-
266050	3/4" F	2- 7	1	-
266054	3/4" F	3-10	1	-
266052	3/4" F	7-25	1	-



PUMP STATIONS

269

Pump station for solar thermal systems, flow and return connection, **with solar controller**.
 Supply: 230 V (ac).
 Max. working pressure: 10 bar.
Safety relief valve temperature range: -30-160°C.
 Safety relief valve setting: 6 bar (for other settings, see 253 series).
Flow meter temperature range: -10-110°C.
Max. percentage of glycol: 50%.

- Consisting of:
- Solar 15-65 circulation pump;
 - safety relief valve for solar thermal systems 253 series;
 - 2 fill/drain cocks;
 - instrument holder fitting with pressure gauge;
 - flow meter;
 - deaerator device;
 - flow temperature gauge;
 - return temperature gauge;
 - 2 shut-off valves and check valves;
 - 2 hose connections;
 - pre-formed shell **insulation**;
 - digital controller DeltaSol® C+ with probes.



269

Pump station for solar thermal systems, flow and return connection.
 Supply: 230 V (ac).
 Max. working pressure: 10 bar.
Safety relief valve temperature range: -30-160°C.
 Safety relief valve setting: 6 bar (for other settings, see 253 series).
Flow meter temperature range: -10-110°C.
Max. percentage of glycol: 50%.

- Consisting of:
- Solar 15-65 circulation pump;
 - safety relief valve for solar thermal systems 253 series;
 - 2 fill/drain cocks;
 - instrument holder fitting with pressure gauge;
 - flow meter;
 - deaerator device;
 - flow temperature gauge;
 - return temperature gauge;
 - 2 shut-off valves and check valves;
 - 2 hose connections;
 - pre-formed shell **insulation**.



Code	Flow meter scale (l/min)			
269250	3/4" F 1-13	1	-	

Code	Flow meter scale (l/min)			
269050	3/4" F 1-13	1	-	

PUMP STATIONS

268

Pump station for solar thermal systems, return connection, **with solar controller**.
 Supply: 230 V (ac).
 Max. working pressure: 10 bar.
Safety relief valve temperature range: -30–160°C.
 Safety relief valve setting: 6 bar (for other settings, see 253 series).
Flow meter temperature range: -10–110°C.
Max. percentage of glycol: 50%.

- Consisting of:
- Solar 15-65 circulation pump;
 - safety relief valve for solar thermal systems 253 series;
 - fill/drain cock;
 - instrument holder fitting with pressure gauge;
 - flow meter;
 - return temperature gauge;
 - shut-off valve and check valve;
 - 2 hose connections;
 - pre-formed shell **insulation**;
 - digital controller DeltaSol® C+ with probes.



268

Pump station for solar thermal systems, return connection.
 Supply: 230 V (ac).
 Max. working pressure: 10 bar.
Safety relief valve temperature range: -30–160°C.
 Safety relief valve setting: 6 bar (for other settings, see 253 series).
Flow meter temperature range: -10–110°C.
Max. percentage of glycol: 50%.

- Consisting of:
- Solar 15-65 circulation pump;
 - safety relief valve for solar thermal systems 253 series;
 - fill/drain cock;
 - instrument holder fitting with pressure gauge;
 - flow meter;
 - return temperature gauge;
 - shut-off valve and check valve;
 - 2 hose connections;
 - pre-formed shell **insulation**.



Code	Flow meter scale (l/min)			
268250	3/4" F 1-13	1	1	-

Code	Flow meter scale (l/min)			
268050	3/4" F 1-13	1	1	-



**ACCESSORIES
FOR PUMP STATIONS**



259 ●

tech. broch. 01136

Welded expansion vessel only for primary circuit of solar thermal systems.
Diaphragm certified to DIN 4807-3 standard.
Max. percentage of glycol: 50%.
Max. working pressure: 10 bar.
Diaphragm max. temperature: 100°C.
System temperature range: -10-120°C.



Code	Litres	Conn.	Precharge (bar)		
259012	12	3/4"	2,5	1	-
259018	18	3/4"	2,5	1	-
259024	24	3/4"	2,5	1	-
259035	35	3/4"	2,5	1	-
259050	50	3/4"	2,5	1	-



255 ●

tech. broch. 01136

Expansion vessel connection kit.
Consisting of:
- stainless steel flexible hose (L=500 mm);
- automatic shut-off cock;
- wall mounting bracket
(for vessels up to 24 litres).

Max. working pressure: 10 bar.
Shut-off cock max. working temperature: 110°C.
Max. percentage of glycol: 50%.

Code			
255001	3/4"	1	-

255 ●

System filling pump for pump stations.



Code			
255010		1	-

**BALL VALVE AND
THREE-PIECE UNION FITTING**



240

Ball valve for solar thermal system.
Body and ball in stainless steel AISI 316.
PN 63.
Female connections.
Handle in stainless steel AISI 304.
Temperature range: -30-200°C.
Max. percentage of glycol: 50%.

Code			
240400	1/2"	1	-
240500	3/4"	1	-
240600	1"	1	-



588

Three-piece straight union fitting for solar thermal systems.
Max. working pressure: 16 bar.
Temperature range: -30-160°C.
Max. percentage of glycol: 50%.
Black nickel plated nut.

Code			
588052	3/4" F x M with union	1	25
588062	1" F x M with union	1	20

DIGITAL CONTROLLER

257 • SOLCAL 1

Digital controller for solar thermal systems. Complete with wall mounting basis for plug-in electrical connection. Complete with three probes type Pt1000. Double relays output. Supply: 230 V ±6% - 50 Hz. Power consumption: 4 VA. Max. contact rating: 250 V (ac) - 8 (2) A. Protection class: IP 40.



Code **257041** 1 -

Characteristic components

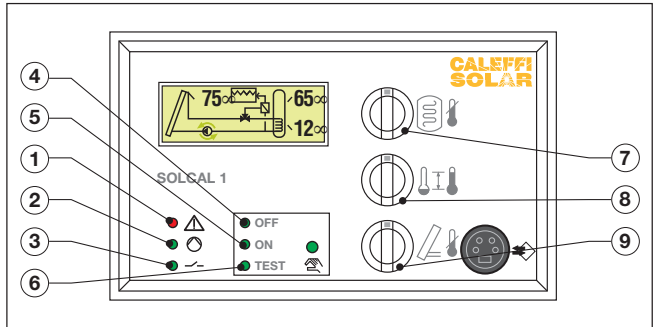

- 1) LED 1: function error or probe fault (red)
- 2) LED 2: Solar circuit pump ON
- 3) LED 3: second relays output active
- 4) LED 4: OFF regulator non active
- 5) LED 5: ON regulator active
- 6) LED 6: active relays test
- 7) Storage temperature control setting at level 1, at level 2 depending on programme (see system)
- 8) Δt min. and max. control
- 9) Min. temperature control for solar panel activation and min. working time

Regulation programs

The controller allows to manage 11 regulation programs, depending on the possible system configurations. They can be used for systems with single or double storage, swimming-pools, heating or domestic water systems, etc..



257 • Pocket for Pt1000 probe. In steel. Length: 100 mm.

Code **257004** 1/2" 1 -

Application diagram of controller 257 series

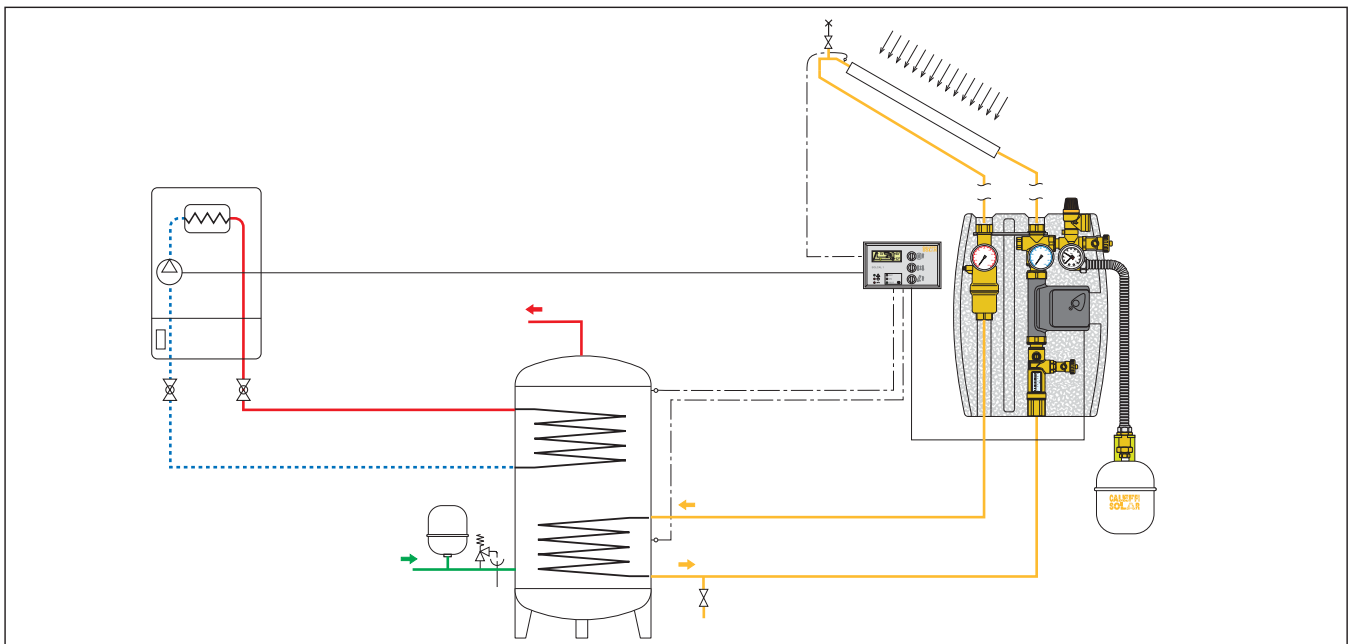

DIFFERENTIAL REGULATORS AND THERMOSTAT





257 •  **tech. broch. 01143**

Differential temperature regulator for solar thermal systems, with relays output. Complete with contact probe and immersion probe with pocket.
 Box protection class: IP 65.
 Supply: 230 V ±6% - 50 Hz.
 Nominal power consumption: 1,45 VA.
 Contact rating on switch-over: 6 A (230 V).
 ΔT adjustment range: 2–20 K.
 Hysteresis: 2 K (±1 K).



 

Code		
257010	1	–





257 •  **tech. broch. 01143**

Box complete with DIN bar, for regulator or thermostat 257 series.
 Protection class: IP 65.



 

Code	(h x w x d)	
257001	200 x 122 x 47	1 –





257 •  **tech. broch. 01143**

Double box complete with DIN bar, for regulator and thermostat 257 series.
 Protection class: IP 65.



 

Code	(h x w x d)	
257003	200 x 160 x 47	1 –





257 •  **tech. broch. 01143**

Differential temperature regulator for solar thermal systems, with relays output.
 Box protection class: IP 65.
 Supply: 230 V ±6% - 50 Hz.
 Nominal power consumption: 1,45 VA.
 Contact rating on switch-over: 6 A (230 V).
 ΔT adjustment range: 2–20 K.
 Hysteresis: 2 K (±1 K).



 

Code		
257000	1	–





150 •  **tech. broch. 01143**

Contact probe for regulator or thermostat 257 series and for regulator 1520 series (flow or return).
 Cable length: 2 m.



 

Code		
150009	1	–





257 •  **tech. broch. 01143**

Thermostat for solar thermal systems, with relays output. For thermal integration control and diverter valves.
 Box protection class: IP 65.
 Supply: 230 V ±6% - 50 Hz.
 Nominal power consumption: 1,45 VA.
 Contact rating on switch-over: 6 A (230 V).
 Adjustment temperature range: 20–90°C.
 Hysteresis: 1 K.



 

Code		
257002	1	–





150 •  **tech. broch. 01143**

Contact probe for regulator or thermostat 257 series and for regulator 1520 series.
 Cable length: 2 m.



 

Code		
150006	1	–



150 •  **tech. broch. 01143**

Pocket for immersion probe
 code 150006.

Code		
150029	1/4" M	1 –

MECHANICAL FITTINGS WITH O-RING SEAL



2540

Female fitting, mechanical O-Ring seal for solar thermal systems.
For annealed copper, hard copper, brass, mild and stainless steel pipes.
Max. working pressure: 16 bar.
Temperature range: -30-160°C.
Max. percentage of glycol: 50%.
Black nickel plated nut.

Code			
254055	3/4" F - Ø 15	1	25
254058	3/4" F - Ø 18	1	25
254052	3/4" F - Ø 22	1	25
254062	1" F - Ø 22	1	25
254068	1" F - Ø 28	1	25



2545

Elbow coupling sleeve, mechanical O-Ring seal for solar thermal systems.
For annealed copper, hard copper, brass, mild and stainless steel pipes.
Max. working pressure: 16 bar.
Temperature range: -30-160°C.
Max. percentage of glycol: 50%.
Black nickel plated nut.

Code			
254505	Ø 15	1	25
254508	Ø 18	1	25
254502	Ø 22	1	25



2543

Coupling sleeve, mechanical O-Ring seal for solar thermal systems.
For annealed copper, hard copper, brass, mild and stainless steel pipes.
Max. working pressure: 16 bar.
Temperature range: -30-160°C.
Max. percentage of glycol: 50%.
Black nickel plated nut.

Code			
254305	Ø 15	1	25
254308	Ø 18	1	25
254302	Ø 22	1	25



2547

Male elbow fitting, mechanical O-Ring seal for solar thermal systems.
For annealed copper, hard copper, brass, mild and stainless steel pipes.
Max. working pressure: 16 bar.
Temperature range: -30-160°C.
Max. percentage of glycol: 50%.
Black nickel plated nut.

Code			
254755	3/4" M - Ø 15	1	25
254758	3/4" M - Ø 18	1	25
254752	3/4" M - Ø 22	1	25



2544

Male fitting, mechanical O-Ring seal for solar thermal systems.
For annealed copper, hard copper, brass, mild and stainless steel pipes.
Max. working pressure: 16 bar.
Temperature range: -30-160°C.
Max. percentage of glycol: 50%.
Black nickel plated nut.

Code			
254455	3/4" M - Ø 15	1	25
254458	3/4" M - Ø 18	1	25
254452	3/4" M - Ø 22	1	25
254465	1" M - Ø 15	1	25
254462	1" M - Ø 22	1	25



2548

Female elbow fitting, mechanical O-Ring seal for solar thermal systems.
For annealed copper, hard copper, brass, mild and stainless steel pipes.
Max. working pressure: 16 bar.
Temperature range: -30-160°C.
Max. percentage of glycol: 50%.
Black nickel plated nut.

Code			
254855	3/4" F - Ø 15	1	25
254858	3/4" F - Ø 18	1	25
254852	3/4" F - Ø 22	1	25



2540

Plug for Ø 22 copper pipe.

Code			
254002	Ø 22	1	25

PUMP STATIONS WITH HEAT EXCHANGER

260

Pump station with heat exchanger, for solar water storages.
 Electric supply: 230 V (ac).
 Max. working pressure: 6 bar.
Temperature range: 0–120°C.
Solar circuit safety relief valve temperature range: -30–160°C.
Max. percentage of glycol: 50%.
 Safety relief valve setting: 6 bar (solar circuit);
 3 bar (storage circuit).

- Consisting of:
- solar circuit circulation pump;
 - storage circuit circulation pump;
 - brazed heat exchanger, in stainless steel;
 - shut-off valves with check device for solar circuit;
 - shut-off valves with check device for storage circuit;
 - instrument holder fitting with pressure gauge;
 - safety relief valves;
 - fill/drain cocks;
 - motorised diverter valve;
 - pre-formed shell **insulation**;
 - digital controller with probes.



Code
260531 3/4" primary x 3/4" secondary

1

-

261

Unit for instantaneous domestic hot water production.
 Electric supply: 230 V (ac).
 Max. working pressure: 6 bar.
Temperature range: 2–95°C.
Max. percentage of glycol: 50%.

- Consisting of:
- storage circuit circulation pump;
 - domestic water recirculation pump;
 - brazed heat exchanger, in stainless steel;
 - shut-off valves with check valve for storage circuit;
 - obturator shut-off valves for domestic water circuit;
 - fill/drain cocks;
 - pre-formed shell **insulation**;
 - digital controller with probes.



Code
261531 3/4" primary x 1" secondary

1

-

Application diagram of 260 and 261 series

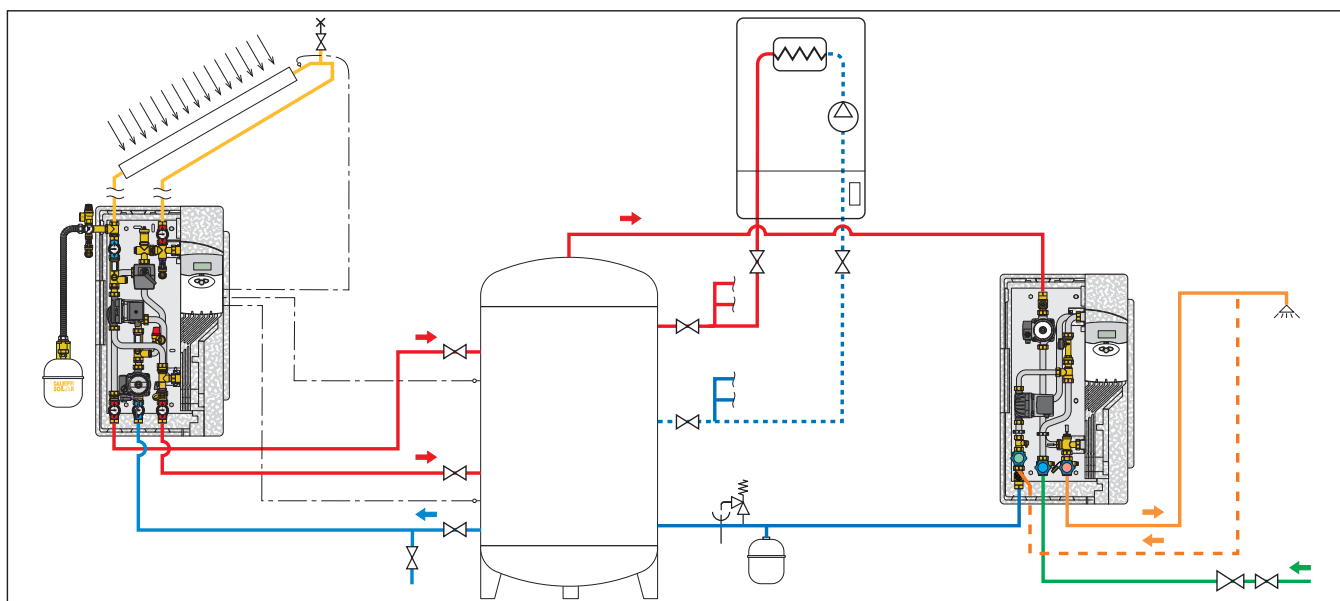

HEAT METER

75525
CONTECA SOLAR



 tech. broch. 01146

Direct heat metering with local LCD reading by means or centralised reading with controller code 755010 or interface 75505. series, for solar thermal systems.

Max. working pressure: 10 bar.
Temperature range: 5–120°C.
Max. percentage of glycol: 50%.

The CONTECA SOLAR module is supplied complete with:
- Pair of temperature probes with immersion pockets.
- Y pockets for immersion probes.
- Water meter, with pulse output (max. temperature 120°C).
- Electronic integrator with LCD.
- Electric supply 24 V (ac) 50 Hz - 1 W.
- Set for transmission in M Bus mode.
Conformity to EN 1434-1.



Code	Conn.	Meas. type	Q _{nom} m ³ /h		
755254	1/2"	single jet	1,5	1	–
755255	3/4"	single jet	2,5	1	–
755256	1"	multi jet	3,5	1	–

BALANCING VALVE WITH FLOW METER



258

 tech. broch. 01148



Balancing valve with flow meter, for solar thermal systems.
Direct reading of flow rate.
Brass valve body and flow meter.
Chrome plated.
Ball valve for flow rate adjustment.
Graduated scale flow meter with magnetic movement flow rate indicator.

With insulation.
Max. working pressure: 10 bar.
Temperature range: -30–130°C.
Max. percentage of glycol: 50%.
Patent application
No. MI2007A000703.

Code	Flow rate range (l/min)		
258503	3/4" 2–7	1	5
258533	3/4" 3–10	1	5
258523	3/4" 7–28	1	5
258603	1" 10–40	1	5

Application diagram of heat meter 75525 series and balancing valve 258 series

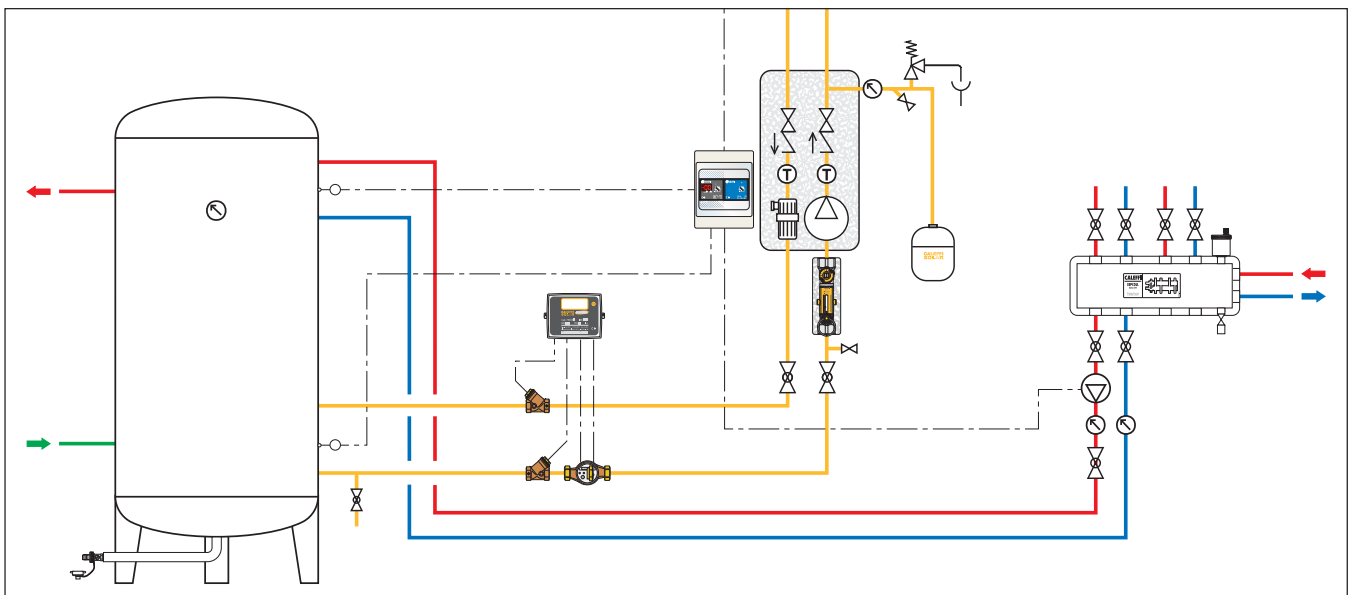



THERMOSTATIC MIXING VALVES



2521  **tech. broch. 01127**
Adjustable thermostatic mixing valve for solar thermal systems.
CR dezincification resistant alloy body. Chrome plated.
Male union connections.
Max. working pressure: 14 bar.
Max. inlet temperature: 100°C.





Code	Temperature adjustment	Kv (m³/h)		
252140	1/2"	30-65°C	2,6	1 10
252150	3/4"	30-65°C	2,6	1 10

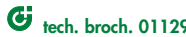

2523  **tech. broch. 01129**
Thermostatic mixing valve with interchangeable cartridge for solar thermal systems.
Brass body. Chrome plated.
Male union connections.
Max. working pressure: 14 bar.
Max. inlet temperature: 110°C.





Code	Temperature adjustment	Kv (m³/h)		
252340	1/2"	30-65°C	4,0	1 10
252350	3/4"	30-65°C	4,5	1 10
252360	1"	30-65°C	6,9	1 -
252370	1 1/4"	30-65°C	9,1	1 -



2521  **tech. broch. 01127**
Adjustable thermostatic mixing valve, **with check valves**, for solar thermal systems.
CR dezincification resistant alloy body. Chrome plated.
Male union connections.
Max. working pressure: 14 bar.
Max. inlet temperature: 100°C.



Code	Temperature adjustment	Kv (m³/h)		
252153	3/4"	30-65°C	2,6	1 10



2523
Spare cartridge.
For thermostatic mixing valve 2523 series.

Code	Temperature adjustment		
252305	1/2" - 3/4"	1	-



2523
Spare cartridge.
For thermostatic mixing valve 2523 series.

Code	Temperature adjustment		
252306	1" - 1 1/4"	1	-

Application diagram of mixing valve 2521 series

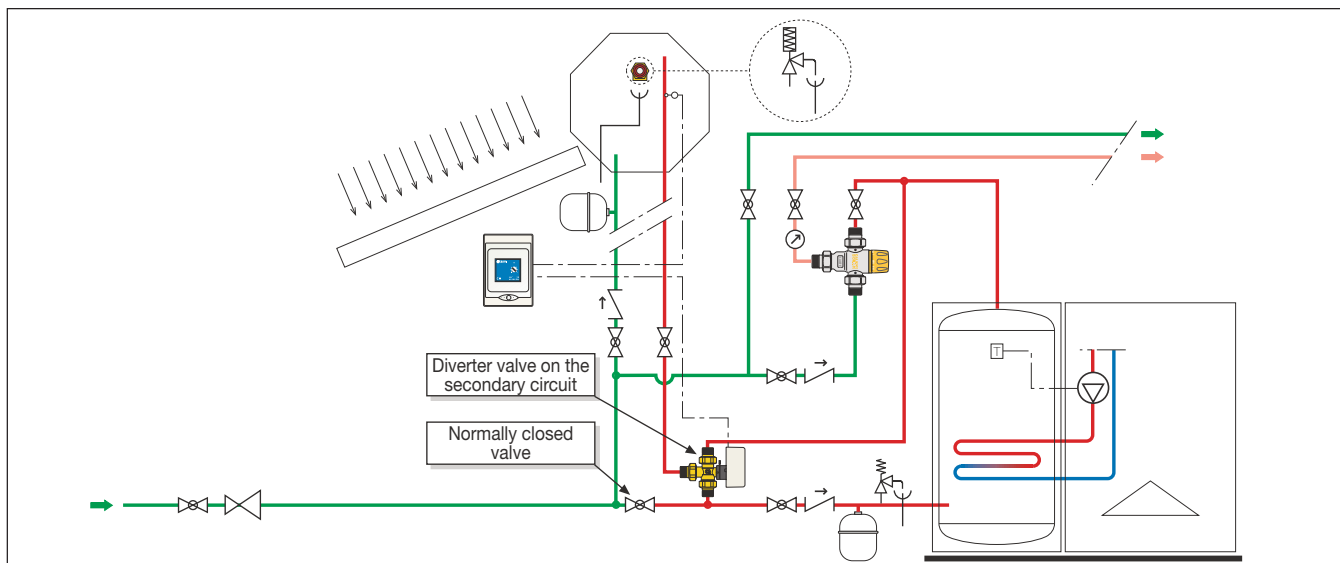

ANTI-SCALD TEMPERING AND THERMOSTATIC MIXING VALVES

2522



High performance adjustable anti-scald tempering valve **with check valves and strainers** at the inlets. Suitable for solar and instantaneous hot water systems. **CR** dezincification resistant alloy body. Chrome plated. Male union connections. Max. working pressure: 1400 kPa. **Max. inlet temperature: 100°C. Certified to AS 4032.2.**



Code	Temperature adjustment	Kv (m ³ /h)		
252212HP AUS DN 15	35–55°C	1,5	1	10
252219HP AUS DN 20	35–55°C	1,7	1	10

2527

tech. broch. 01165



Adjustable anti-scald thermostatic mixing valve, **with check valves and strainers**, for solar thermal systems. High thermal performance device, **with anti-scald safety function.** **CR** dezincification resistant alloy body. Chrome plated. Male union connections. Performance to standards NF 079 doc. 8, EN 15092, EN 1111, EN 1287. Max. working pressure: 10 bar. **Max. inlet temperature: 100°C.**

Code	Temperature adjustment	Kv (m ³ /h)		
252714 1/2"	35–55°C	1,5	1	10
252713 3/4"	35–55°C	1,7	1	10

MOTORISED BALL DIVERter VALVE

6443



Motorised three-way ball diverter valve. Max. working pressure: 10 bar. Max. Δp: 10 bar. Temperature range: -5–110°C.

Complete with actuator with 3-contact control. With auxiliary microswitch. Electric supply: 230 V (ac). Power consumption: 8 VA. Auxiliary microswitch contact rating: 0,8 A (230 V). Ambient temperature range: 0–55°C. Protection class: IP 44 (vertical stem). IP 40 (horizontal stem). **Operating time: 10 s** (90° rotation). Cable length: 100 cm. Patent application No. MI2005A001282.



Code	Electric supply V	Kv (m ³ /h)		
644346 1/2"	230	3,9	1	5
644356 3/4"	230	3,9	1	5
644357 3/4"	230	8,9	1	5
644366 1"	230	9	1	5

SOLAR STORAGE-BOILER CONNECTION KIT

264 SOLARNOCAL

tech. broch. 01163



Function

A thermostatic anti-scald mixing valve, at the kit inlet, controls the temperature of the water coming from the solar hot water storage. The thermostat, by means of the probe positioned on the hot water flow from the solar hot water storage, controls the diverter valve at the kit outlet. Depending on the temperature setting, the valve diverts the water towards the user circuit or activates the boiler circuit, **without thermal integration**.

Hydraulic diagrams

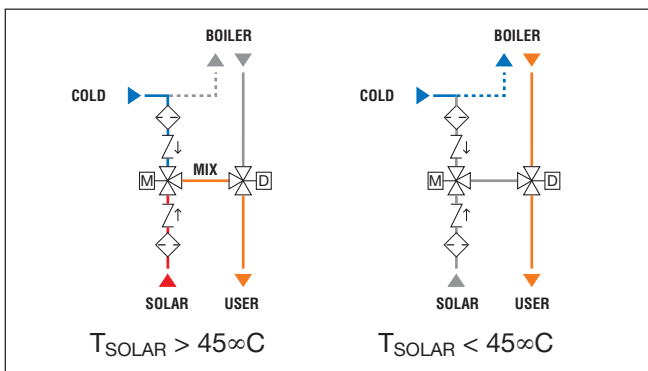

Solar storage-boiler connection kit, **without thermal integration**.

Consisting of:

- thermostatic anti-scald mixing valve, adjustable with knob, for solar thermal systems. Complete with strainers and check valves at the inlets;
- diverter valve with three-contact actuator, with auxiliary microswitch;
- thermostat with probe for solar thermal system, for operating diverter valve. Position indicator LED.
- pre-formed **shell protective cover**.

Diverter-mixing valve coupling with adjustable position of the inlet and outlet connections.

Mixing valve

CR dezincification resistant alloy body. Chrome plated.

Max. working pressure: 10 bar.
Adjustment temperature range: 35–55°C.

Max. inlet temperature: 100°C.

Diverter valve

Brass body. Chrome plated.

Max. working pressure: 10 bar.
Temperature range: -5–110°C.

Actuator

Three-contact type.

Supply: 230 V (ac).

Power consumption: 8 VA.

Auxiliary microswitch contact rating: 0,8 A (230 V).

Ambient temperature range: 0–55°C.

Protection class: IP 44 (vertical stem).
IP 40 (horizontal stem).

Operating time: 10 s.

Cable length: 1 m.

Thermostat with probe

Supply: 230 V (ac).

Adjustable temperature range: 25–55°C.

Factory setting: 45°C.

Box protection class: IP 65.

Patent application No. MI2007A000936.

Code

264352 3/4"



1

Application diagram of Solarnocal kit 264 series

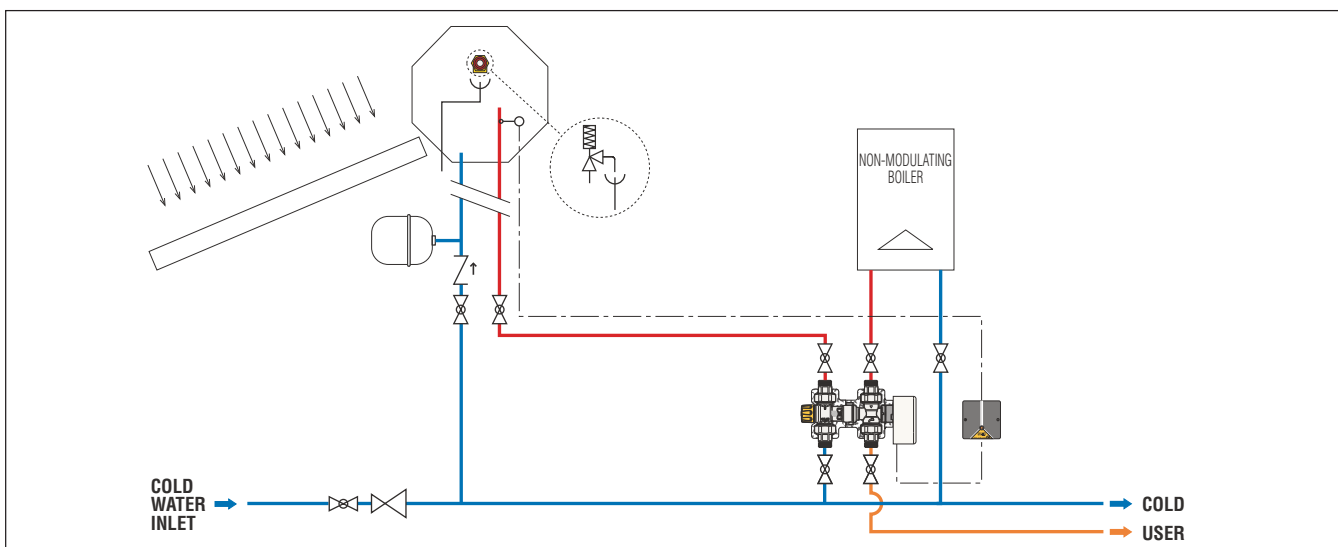

SOLAR STORAGE-BOILER CONNECTION KIT

265 SOLARINICAL

tech. broch. 01163



Function

The thermostat, by means of the probe positioned on the hot water flow from the solar hot water storage, controls the diverter valve at the kit inlet. Depending on the temperature setting, the valve diverts the water towards the user circuit or the boiler circuit, **with thermal integration**. A thermostatic anti-scald mixing valve, at the kit outlet, constantly controls the temperature of the water sent to the user.

Hydraulic diagrams

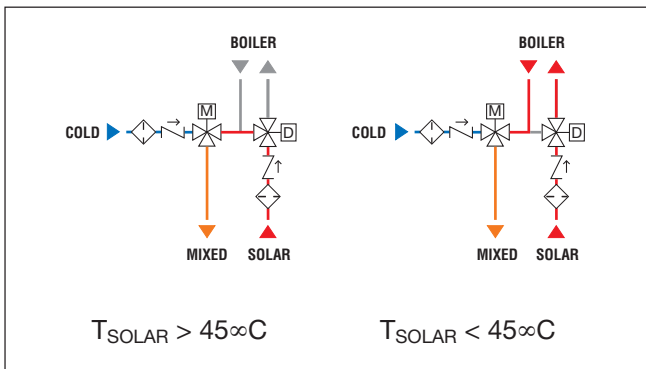

Solar storage-boiler connection kit, **with thermal integration**.

- thermostatic anti-scald mixing valve, adjustable with knob, for solar thermal systems. Complete with strainers and check valves at the inlets;
- diverter valve with three-contact actuator, with auxiliary microswitch;
- thermostat with probe for solar thermal system, for operating diverter valve. Position indicator LED.
- pre-formed **shell protective cover**.

Diverter-mixing valve coupling with adjustable position of the inlet and outlet connections.

Mixing valve

CR dezincification resistant alloy body. Chrome plated.
Max. working pressure: 10 bar.
Adjustment temperature range: 35–55°C.
Max. inlet temperature: 100°C.

Diverter valve

Brass body. Chrome plated.
Max. working pressure: 10 bar.
Temperature range: -5–110°C.

Actuator

Three-contact type.
Supply: 230 V (ac).
Power consumption: 8 VA.
Auxiliary microswitch contact rating: 0,8 A (230 V).
Ambient temperature range: 0–55°C.
Protection class: IP 44 (vertical stem).
IP 40 (horizontal stem).
Operating time: 10 s.
Cable length: 1 m.

Thermostat with probe

Supply: 230 V (ac).
Adjustable temperature range: 35–50°C.
Factory setting: 45°C.
Box protection class: IP 65.
Patent application No. MI2007A000936.

Code

265352 3/4"



1

-

Spare parts for connection kit 264 and 265 series.

Code

- F29468 control thermostat for 264 series
- F29469 control thermostat for 265 series
- F29399 actuator
- F29466 probe
- F29467 pocket probe
- F29488 Ø 6 mm probe

Application diagram of Solarinical kit 265 series

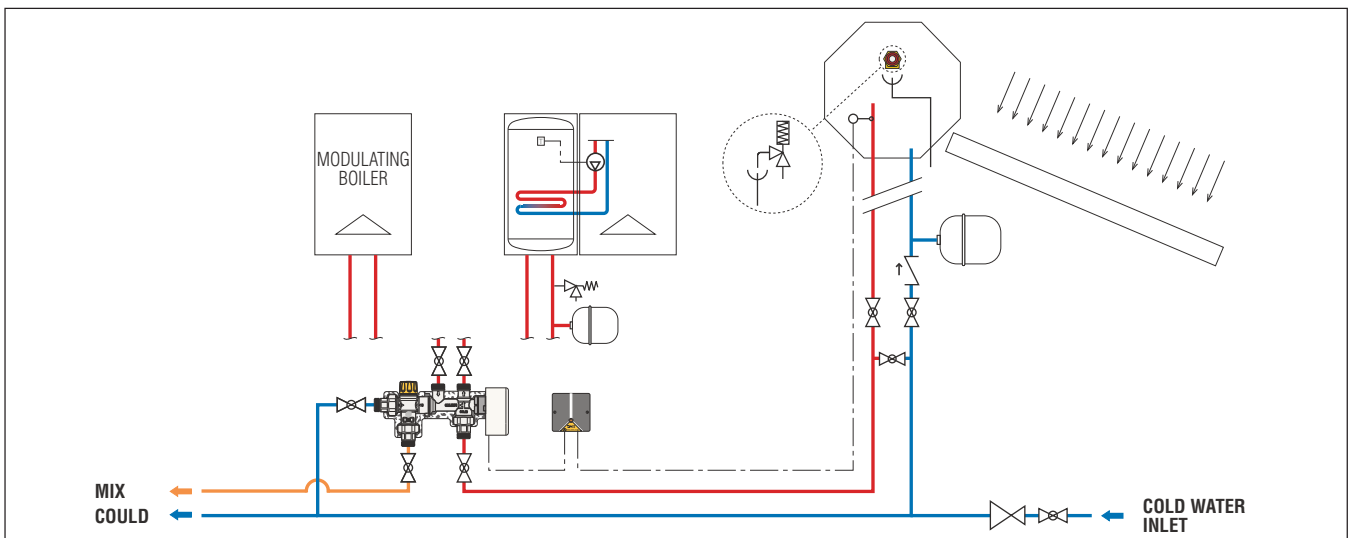

SOLAR STORAGE-BOILER THERMOSTATIC CONNECTION KIT

262 SOLARINCAL-T

tech. broch. 01164



Function

A thermostatic diverter valve, at the kit inlet, receives hot water coming from the solar water storage. Depending on the temperature setting, the valve diverts the water automatically and in a proportional manner towards the user circuit or the boiler with storage circuit, with thermal integration. The valve modulates the flow rates to optimise the energy contained in the solar storage and reduce boiler operation times to a minimum. A thermostatic anti-scald mixing valve, at the kit outlet, constantly controls and limits the temperature of the water sent to the user.

Solar storage-boiler connection kit, with thermal integration.

- Consisting of:
 - thermostatic anti-scald mixing valve, adjustable with knob, for solar thermal systems. Complete with strainers and check valves at the inlets.
 - thermostatic diverter valve;
 - pre-formed shell protective cover.

Diverter-mixing valve coupling with adjustable position of the inlet and outlet connections.

Mixing valve

CR dezincification resistant alloy body. Chrome plated. Max. working pressure: 10 bar. Adjustment temperature range: 35–55°C. Max. inlet temperature: 100°C. Performance to standards NF 079 doc. 8, EN 15092, EN 1111, EN 1287.

Diverter valve

Brass body. Chrome plated. Max. working pressure: 10 bar. Factory setting: 45°C. Max. inlet temperature: 100°C.

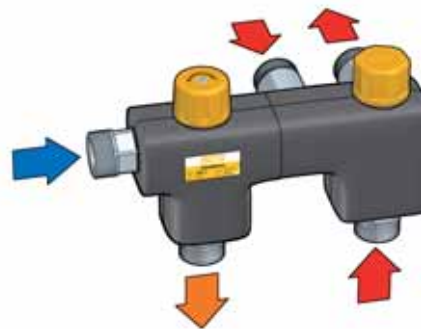

Hydraulic diagrams

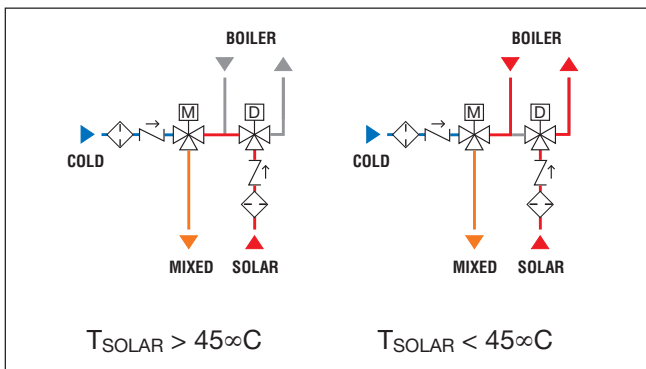

Code

262350 3/4"

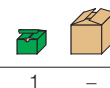

1

Application diagram of SolarincaI-T kit 262 series

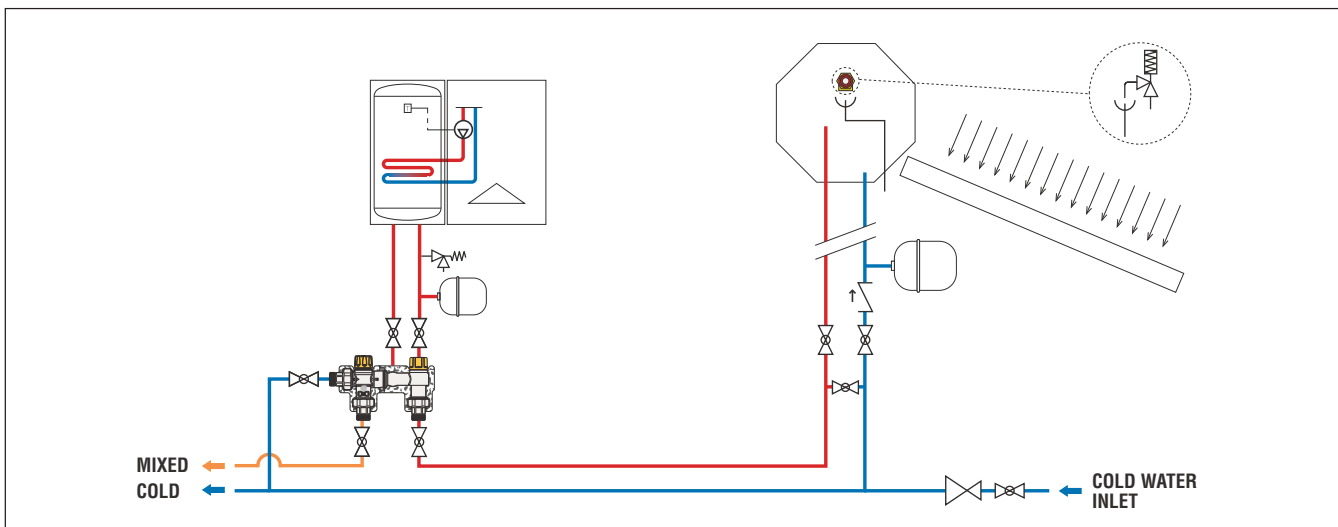

SOLAR STORAGE-BOILER THERMOSTATIC CONNECTION KIT

263
SOLARINCAL-T PLUS

tech. broch. 01164



Function

A thermostatic diverter valve, at the kit inlet, receives hot water coming from the solar water storage. Depending on the temperature setting, the valve diverts the water automatically and proportionally towards the user circuit or the **instantaneous boiler circuit, with thermal integration**. The valve modulates the flow rates to optimise the energy contained in the solar storage and reduce boiler operation times to a minimum. A specific thermostatic control device limits the boiler inlet temperature to prevent it being switched on and off too often, which leads to hunting and irregular operation. A thermostatic anti-scald mixing valve, at the kit outlet, constantly controls the temperature of the water sent to the user.

Solar storage-boiler connection kit, **with thermal integration**.

Consisting of:

- thermostatic anti-scald mixing valve, adjustable with knob, for solar thermal systems. Complete with strainers and check valves at the inlets;
- thermostatic diverter valve;
- thermostatic control device;
- pre-formed **shell protective cover**.

Mixing valve

CR dezincification resistant alloy body. Chrome plated.

Max. working pressure: 10 bar.

Adjustment temperature range: 35–55°C.

Max. inlet temperature: 100°C.

Performance to standards NF 079 doc. 8, EN 15092, EN 1111, EN 1287.

Diverter valve

CR dezincification resistant alloy body. Chrome plated.

Max. working pressure: 10 bar.

Factory set: 45°C.

Max. inlet temperature: 100°C.

Control device

CR dezincification resistant alloy body. Chrome plated.

Factory setting: 30°C.

Max. inlet temperature: 85°C.

Patent application No. MI2008A001813.

Hydraulic diagrams

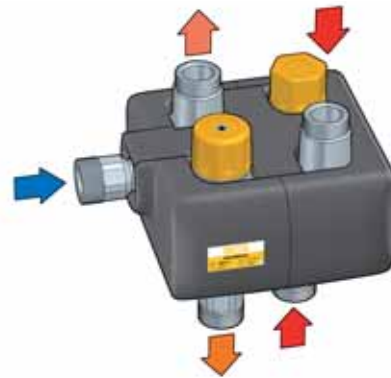
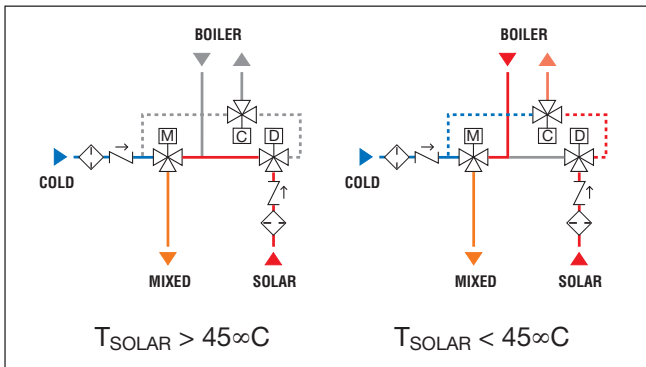

Code

263350 3/4"



1

-

Application diagram of Solarincal-T Plus kit 263 series

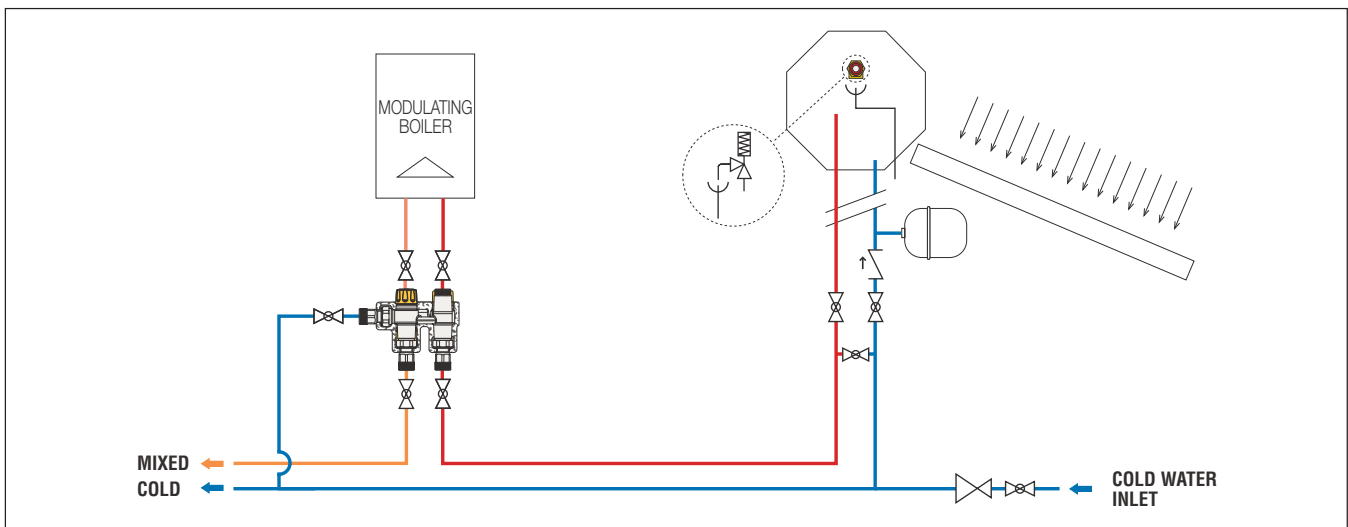

TEMPERATURE AND PRESSURE RELIEF VALVE



309

tech. broch. 01147

Temperature and pressure relief valve.

For solar thermal systems, to protect the hot water storage.

CR dezincification resistant alloy. Chrome plated.

Setting temperature: 90°C.

Discharge rating: 1/2" x Ø 15: 10 kW.

3/4" x Ø 22: 25 kW.

Settings: 6 - 7 - 10 bar.

Settings certified to EN 1490: 7 - 10 bar.



Code

Code	1/2" M x Ø 15	6 bar	1	20
309461	1/2" M x Ø 15	6 bar	1	20
309471	1/2" M x Ø 15	7 bar	1	20
309401	1/2" M x Ø 15	10 bar	1	20
309561	3/4" M x Ø 22	6 bar	1	20
309571	3/4" M x Ø 22	7 bar	1	20
309501	3/4" M x Ø 22	10 bar	1	20

Function

The temperature and pressure relief valve controls and limits the temperature and pressure of the hot water contained in a solar domestic water storage heater and prevents it to reach temperatures over 100°C, with the formation of steam.

On reaching the settings, the valve discharges a sufficient amount of water into the atmosphere so that the temperature and pressure return within the system's operating limits.

As the temperature and pressure decrease, the opposite action occurs with the valve subsequently reclosing within the set tolerances.

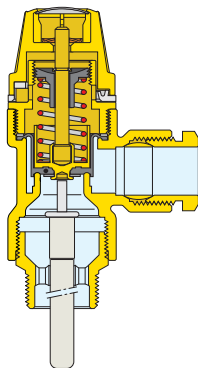

Product certification in accordance with European Standard EN 1490

European Standard EN 1490: 2000, entitled "Building valves - Combined temperature and pressure relief valves - Tests and requirements", describes the constructional and performance specifications that TP relief valves must have.

Caleffi 309 series TP relief valves for solar systems are certified by Buildcert (UK) to comply with the requirements of the European Standard EN 1490.

Application diagram of valve 309 series on a solar hot water storage

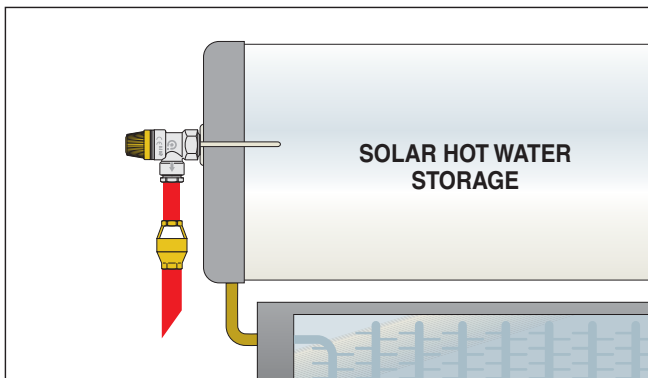

ANTI-FREEZE SAFETY DEVICE



603

ICECAL®

tech. broch. 01181

Anti-freeze safety device.

For hydraulic and solar systems, to protect the storage and the circuit.

Brass body. Chrome plated.

Max. working pressure: 10 bar.

Ambient temperature range: -30-90°C.

Opening temperature: 3°C.

Closing temperature: 4°C.

Patent application No. MI2009U000006.

Code

Code	1/2" F nut	1	-
603041	1/2" F nut	1	-

Function

The anti-freeze safety device prevents ice build-up in domestic water circuits, thereby avoiding possible damage to water storages and pipes.

When the minimum ambient operating temperature is reached, it automatically opens so that a minimum quantity of water may flow to the drain, enabling a small continuous inflow of water. This prevents the circuit from freezing.

When the ambient temperature increases or in the event of contact with warmer water, the opposite action occurs, causing the device to shut-off and circuit normal operating conditions to be restored.

Closed position

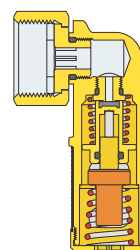

Open position

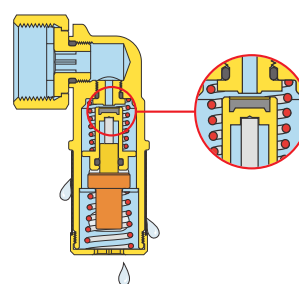

Application diagram of device 603 series on a domestic water circuit

